

SBAP46ME / 72ME / 82ME

The vertical stacker delivery



Features

Standard features:

- Machine control M1 Basic
- Mobile
- Sheet spreading
- Counter for delivered sheets
- SBAP72ME and SBAP82ME: equipment for two-up production
- Integrated pressing station

Optional features:

- Machine control M1 Advanced
- SBAP46ME: equipment for two-up production
- SBAP46ME: automatic feeder stop return with sheet infeed stop for one-up production
- SBAP72ME/SBAP82ME: extension to three-up or four-up production

- SBAP72ME/SBAP82ME: automatic feeder stop return with sheet infeed stop for two-up or three-up production

Benefits:

- Pressing station for perfectly pressed folded products
- Marking device for shifting in package
- Spreading of multiple-up streams facilitates sheet removal
- Large holding capacity due to vertical sheet delivery
- Printing sheets standing on their back to handle even unstable products
- Continuously height-adjustable pile table for ergonomic working height

Technical specifications

		SBAP46ME		SBAP72ME		SBAP82ME	
		mm	inch	mm	inch	mm	inch
Working width	min.	150	6	150	6	150	6
	max.	430	16 1/8	700	27 1/2	850	33 1/2
Sheet length	min.	80	3 1/8	80	3 1/8	80	3 1/8
	max.	300	11 3/4	300	11 3/4	300	11 3/4
Pile length	max.	730	28 3/4	730	28 3/4	730	28 3/4
Infeed height	min.	380	15	380	15	380	15
	max.	950	37 3/8	950	37 3/8	950	37 3/8
Outfeed height (depending on infeed height)	min.	850	33 1/2	850	33 1/2	850	33 1/2
	max.	1,180	46 1/2	1,180	46 1/2	1,180	46 1/2
Pressure		20,000 N					
Speed	min.	30 m/min (98 fpm)					
	max.	160 m/min (525 fpm)					

Floorplan SBAP

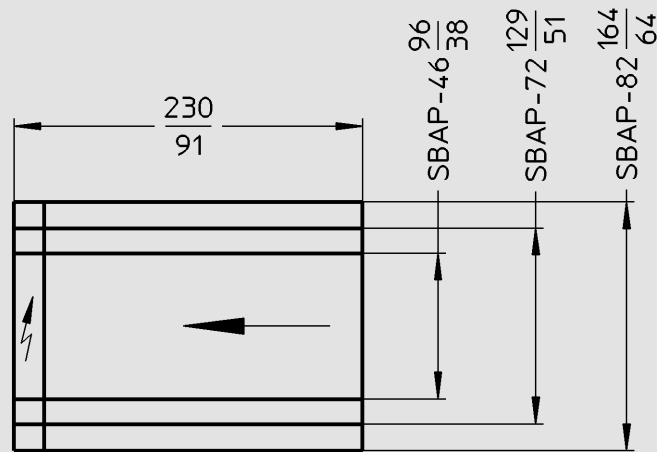

Measurements in $\frac{\text{cm}}{\text{inch}}$

04/2021_v4

MBO Postpress Solutions GmbH

Grabenstrasse 4-6 ■ 71570 Oppenweiler ■ Germany

Phone +49 (0) 7191/46-0 ■ info@mbo-pps.com

www.mbo-pps.com

This datasheet is subject to change without notice.

Technical specifications vary depending upon paper quality.

Your contact person: